

Basis breipatroon poncho four triangle (small).

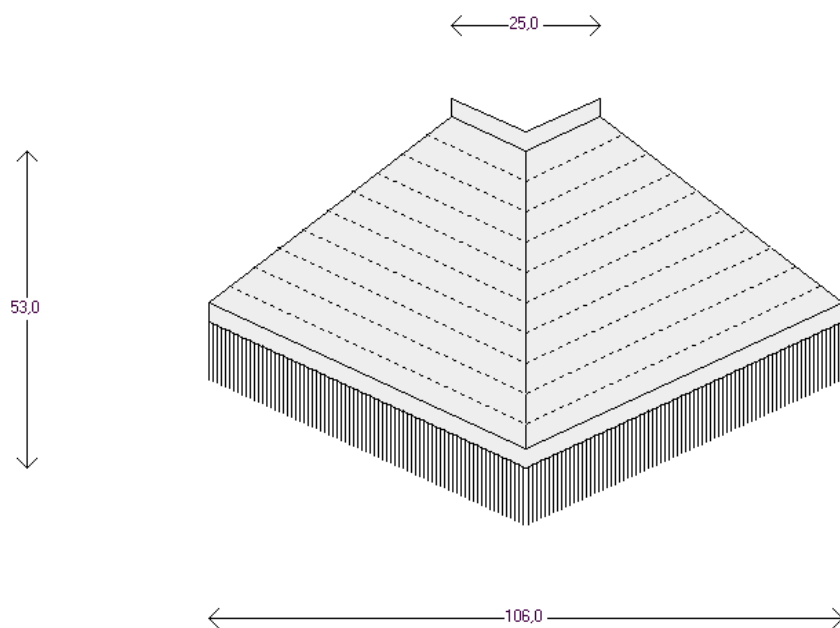

KnitByBart



Breipatroon voor "four triangle" vormige poncho. Je kunt dit patroon zelf creatief invullen met bv verschillende kleuren of fair-isle patronen.

Stekenproef:

26 st x 32 nld = 10 x 10 cm

Brei een proeflapje.

Naalden:

Normale breinaalden van 3 en 3,5 m.

Breigaren:

[Natuur / handgeverfde wol, 300 meter / 100 gram.](#)

De naturel wol is erg mooi voor een witte warme poncho, combineer eventueel met de hand geverfde wol.

Size: Standard Woman 86 for public

Date started: 28-10-2012 Finished: *

YARN DESCRIPTION:

Natuurwol; Gebroken wit; Tricot; Wolprogramma

GAUGE DATA:

Gauge (Stocking stitch over 4 in = 10 cm): 26,0 sts by 32,0 rows.

Body knit by hand on 3,5 mm needles

Ribbing knit by hand on 3 mm needles

FINISHED DIMENSIONS: (cms)

Poncho Length:	53,0	Neck Width:	25,0	Border Depth:	3,0
Poncho Width:	106,0	Neck Band:	3,0	Fringe Length:	10,0

PONCHO PANEL BLOCKING DIMENSIONS (Triangle - four pieces):

Top Width:	14,6	Bottom Width:	59,2	Height:	45,0
------------	------	---------------	------	---------	------

Note: Read ALL these instructions thoroughly BEFORE starting to knit.

PONCHO PANEL (make 4 pieces the same, working top to bottom):

1. Cast on 38 sts on size 3,5 needles.
2. Start work in Stocking stitch. Inc 1 st at each end of every 2nd row 32 times, then every 3rd row 26 times to total 154 sts. Work even to total 144 rows. If you will be knitting the border, place sts on holder. If you will be crocheting the border, cast off.

CONSTRUCT THE PONCHO:

1. Sew, graft or crochet the poncho panels together along the side seams.

NECK BAND:

1. Using size 3 needles work a border 3,0 cms deep (approx. 10 rows) around the neckline of the poncho. This is best worked by picking up sts around the neck and working a few rows. Ribbing will help pull in the neckline a bit. If the neckline is very loose, consider working a folded band and inserting a draw string.

BORDER:

1. Work a border 3,0 cms deep around the bottom of the poncho. This should be crocheted or in a non-curling knit stitch to provide stability to the bottom edge of the poncho.

FRINGE:

1. Work a 10,0 cms fringe around the bottom edge of the poncho. Various methods are given in the Help File / User Manual.

FINISHING:

1. Darn/weave/sew in all loose ends.
2. BLOCK. Really, it makes all the difference.

NOTES: