

Basis breipatroon poncho , gesloten cirkelvormig, zijwaarts gebreid.

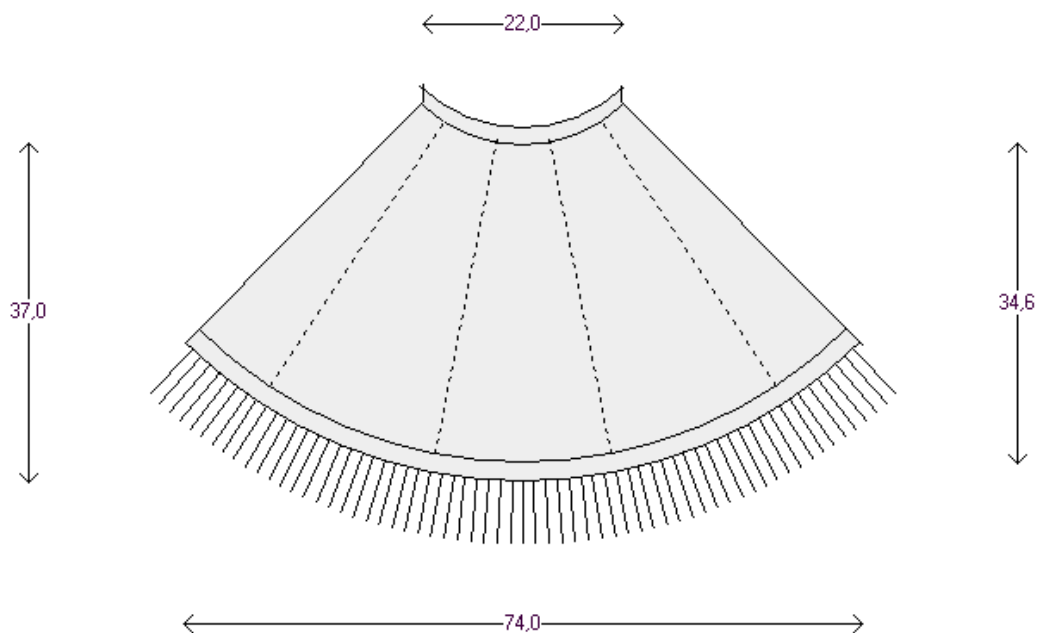

KnitByBart



Breipatroon voor cirkelvormige poncho die overdwers wordt gebreid. Je kunt dit patroon zelf creatief invullen met bv verschillende kleuren.

De beschrijving van het patroon is in het engels.

Een [vertaaltabel](#) is beschikbaar op onze site

Stekenproef:

26 st x 32 nld = 10 x 10 cm

Brei een proeflapje.

Naalden:

Normale breinaalden van 3 en 3,5 m.

Breigaren:

[Naturel / handgeverfde wol , 300 meter / 100 gram.](#)

De naturel wol is erg mooi voor een witte warme poncho , combineer eventueel met de hand geverfde wol.

KNITWARE SKIRTS AND SHAWLS DESIGN

Hip length Closed Circle: Sideways Poncho constructed sideways in 8 wedges

Printed: 2-11-2012

Pattern File Name: 26x32-cirkel_110
Size: Standard Child 110

Date started: 2-11-2012 Finished: *

YARN DESCRIPTION:

Natuurwol; Gebroken wit; Tricot; Wolprogramma

GAUGE DATA:

Gauge (Stocking stitch over 4 in = 10 cm): 26,0 sts by 32,0 rows.

Body knit by hand on 3,5 mm needles

Ribbing knit by hand on 3 mm needles

FINISHED DIMENSIONS: (cms)

Poncho Length:	37,0	Neck Width:	22,0	Border Depth:	2,0
Poncho Width:	74,0	Neck Band:	2,0	Fringe Length:	7,0

Note: Read ALL these instructions thoroughly BEFORE starting to knit.

CIRCLE PONCHOS:

- Circle ponchos are knit sideways in one continuous piece. The start/end edges can be either sewn together at center back (Closed Circle) or left open at center front (Open Circle).
- **BOTTOM** in the instructions below refers to the bottom of the poncho, which will at the left-hand end of your work when the right side is facing you. **TOTAL ROWS** refer to the number of rows at the poncho bottom edge.
- 1. Circle ponchos are worked using **SHORT ROW SHAPING**. You may find using a marker helpful to reduce the amount of counting. The instructions below are fairly brief and are of the form: [short row n1 sts every other row x1 times]. This means:
 - 1A. Wrong side facing. Work the given number (n1) of sts less one. Yarn at back. Slip the next st and wrap the yarn around the st to the front. Return the slipped st to the LH needle without working it.
 - 1B. Turn the piece and work to the end of the row.
 - 1C. Repeat steps 1A and 1B as required (x1 times), working n1 more sts each time.

PONCHO:

1. Cast on 90 sts on size 3,5 needles.
2. Start work in Stocking stitch. The poncho will be worked in 8 wedges, each consisting of an even section and a short-row shaping section. It will start and end with half an even section.
3. Work 14 rows even across all sts. *Work short row shaping as follows: Work 1 row even across all sts. Short row 4 sts every other row 21 times, then 3 sts every other row twice until all sts are in work. Work 15 rows even across all sts.* 76 total rows.
4. Repeat from * to * 6 times more (138, 200, 262, 324, 386, 448 total rows), then work last short row shaping as follows: Work 1 row even across all sts. Short row 5 sts every other row 6 times, then 4 sts every other row 15 times until all sts are in work. 491 total rows. Last half even section: work 15 rows even across all sts. Cast off.

CONSTRUCT THE PONCHO:

1. Sew, graft or crochet the centre back seam.

NECK BAND:

1. Using size 3 needles work a border 2,0 cms deep (approx. 6 rows) around the neckline of the poncho. This is best worked by picking up sts around the neck and working a few rows. Ribbing will help pull in the neckline a bit. If the neckline is very loose, consider working a folded band and inserting a draw string.

BORDER:

1. Work a border 2,0 cms deep around the bottom of the poncho. This should be crocheted or in a non-curling knit stitch to provide stability to the bottom edge of the poncho.

FRINGE:

1. Work a 7,0 cms fringe around the bottom edge of the poncho. Various methods are given in the Help File / User Manual.

FINISHING:

1. Darn/weave/sew in all loose ends.

2. BLOCK. Really, it makes all the difference.