

Basis breipatroon damestrui "Drop".

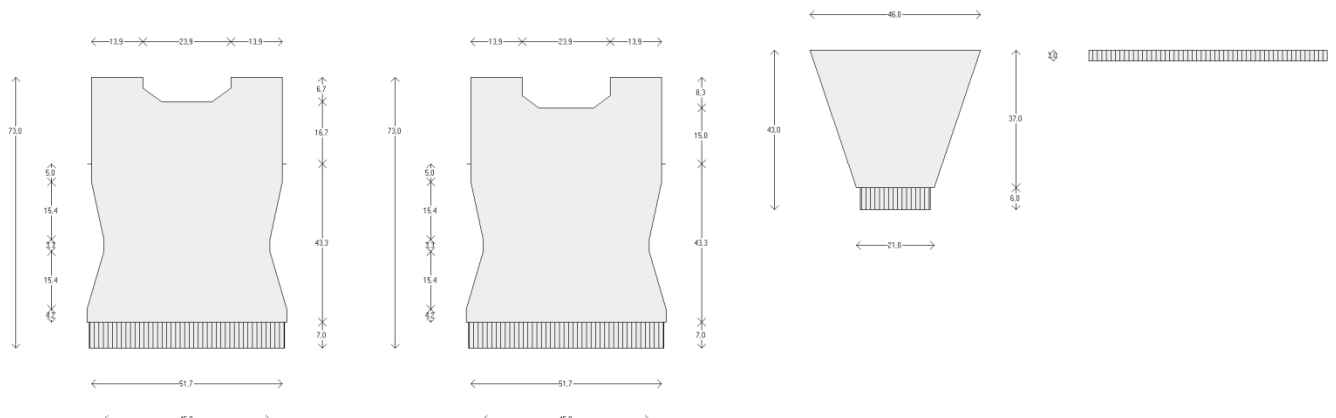

KnitByBart



Breipatroon voor "Drop" dames trui.

Je kunt dit patroon zelf creatief invullen met bv verschillende kleuren of fair-isle patronen.

De beschrijving van het breipatroon is in het engels, [vertaling van de breitermen](#).

Een maattabel staat ook op onze website: [maattabel](#).

Stekenproef:

18 st x 24 nld = 10 x 10 cm

Brei een proeflapje.

Naalden:

Normale breinaalden 3 mm (boorden) en 4 mm.

Breigaren:

[Merinowol in natuurtinten](#)



Flat (Bottom-Up)
Hip length

- row to 97 sts total.
- Change to size 4 needles and Stocking stitch. Work even until piece measures 4,2 cms (10 rows), excluding hem.
 - Waist Shaping. Dec 1 st at each end of next row, then every following 5th row 7 times to 81 sts. Work even for 3,3 cms (8 rows). Inc 1 st at each end of next row, then every following 7th row 5 times to 93 sts. Work even for 5,0 cms (12 rows) to total 43,3 cms, excluding hem.
 - Mark this row at both ends for armhole. Continue until armhole measures 16,7 cms (40 rows).
 - Shape neck. Work both sides at the same time. Work 34 sts. Slip the next 25 sts to a holder. With a second ball of yarn, work remaining 34 sts. Dec 1 st at neck edge every row 9 times, until 25 sts remain.
 - Work even until armhole measures 23,3 cms (56 rows). Cast off 25 shoulder sts loosely.

FRONT:

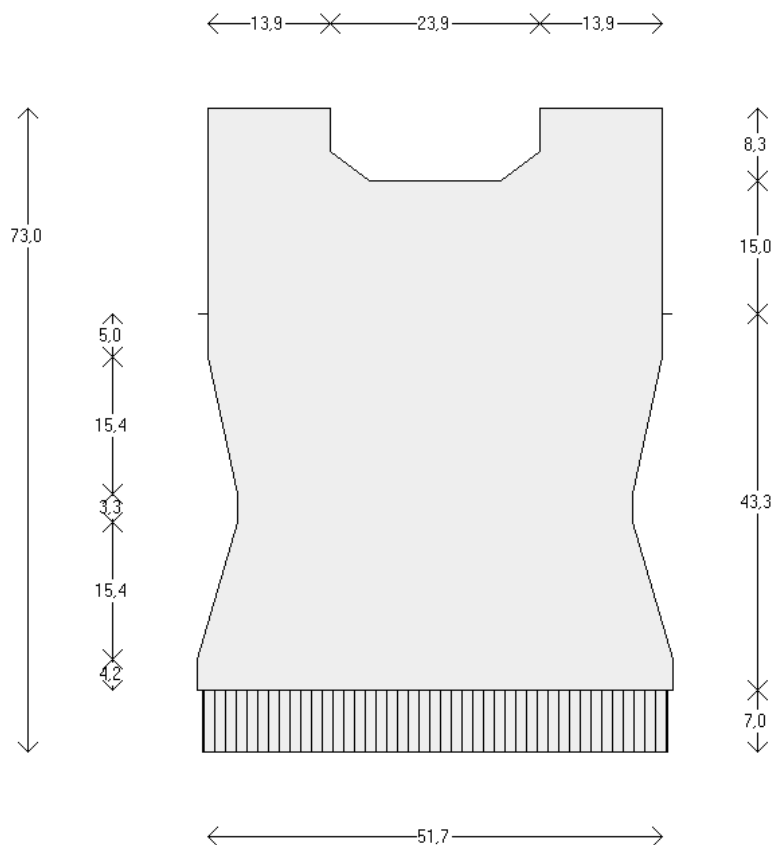

-
- 1-3 Follow steps 1, 2 and 3 as for back.
 - Armhole. Mark this row at both ends for armhole. Continue until armhole measures 15,0 cms (36 rows).
 - Shape neck. Work both sides at the same time. Work 33 sts. Slip the next 27 sts to a holder. With a second ball of yarn, work remaining 33 sts. Dec 1 st at neck edge every row 8 times, until 25 sts remain.
 - Work even until armhole measures 23,3 cms (56 rows). Cast off 25 shoulder sts loosely.

SLEEVES:

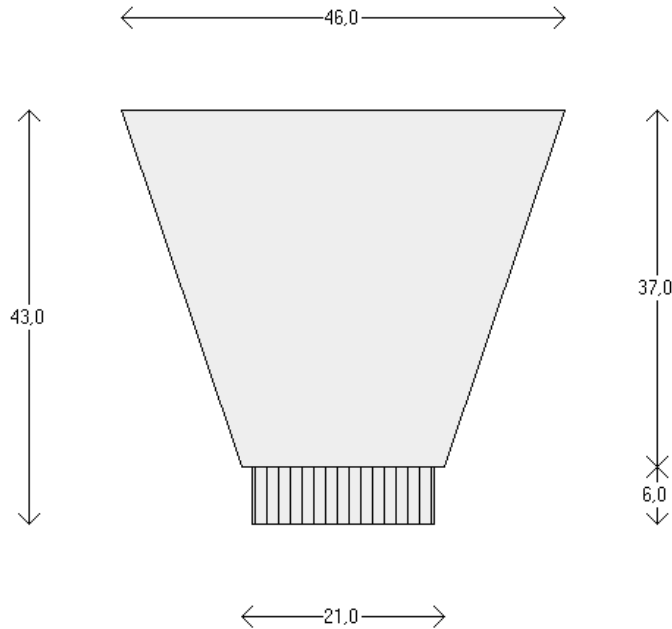

1. Cast on 36 sts on size 3 needles. Work in K1P1 ribbing for 6,0 cms. Inc 4 sts evenly across the row to 40 sts total.
2. Change to size 4 needles and Stocking stitch.
3. Inc 1 st at each end of every 3rd row once, then every 4th row 21 times to 84 sts (87 rows total, excluding hem).
4. Work even until sleeve measures 37,0 cms (90 rows), excluding hem.
5. Cast off loosely.

LEFT SHOULDER SEAM:

1. Sew front to back along left shoulder seam.

BALLET FRONT NECK SINGLE BAND COLLAR:



--- by hand on size 3 needles.

1. With right side of work facing, pick up and work 14 sts from right back neck edge, 25 sts from back neck holder, 14 sts from left back neck edge, 18 sts from left front neck edge, 27 sts from front neck holder and 18 sts from right front neck edge. Total 116 sts.
2. Work 3,0 cms (8 rows) in K1P1 ribbing.
3. Cast off loosely.

FINISHING:

1. Sew sleeve top to armhole, easing to fit. Sew side and sleeve seams. Sew any remaining seams.
2. Darn/weave/sew in all loose ends.

AMOUNT OF YARN REQUIRED TO MAKE GARMENT:

Amount needed:

550 for body and sleeves

100 for ribbing and/or hems

50 for collar/hood
700 Grams TOTAL